

IDEA Technical Data



IDEA Technical Data

VDI 2198

Specification	1.1	Manufacturer		OM	OM	OM	
	1.2	Manufacturer's type designation		IDEA Simplex	IDEA Duplex	IDEA Triplex	
	1.3	Drive: electric, diesel, petrol, gas, mains electric			Electric		
	1.4	Operator type			Standing		
	1.5	Capacity / Load	Q (t)		1		
	1.6	Load centre distance	c (mm)		600		
	1.8	Load distance, centre of drive axle to fork	x (mm)		138 - 196 ⁽³⁾		
	1.9	Distance between axles	y (mm)		966		
	Weights	2.1	Service weight (without battery)	Kg	1595 - 1588 ⁽¹⁾	1698 - 1685 ⁽¹⁾	1822 - 1804 ⁽¹⁾
2.2		Axle loading laden front/rear	Kg	2487 - 2480 ⁽¹⁾ / 493	2583 - 2570 ⁽¹⁾ / 500	2706 - 2688 ⁽¹⁾ / 501	
2.3		Axle loading unladen (front/rear)	Kg	723 - 716 ⁽¹⁾ / 1257	819 - 806 ⁽¹⁾ / 1264	942 - 924 ⁽¹⁾ / 1265	
Wheels and Tyres	3.1	Tyres, solid rubber, super-elastic, polyurethane			Polyurethane		
	3.2	Front wheel dimensions			250 x 80		
	3.3	Rear wheel dimensions			254 x 100		
	3.5	Wheels: number front/rear (x=drive wheels)			2 / 1x		
	3.6	Front tread			770		
	3.7	Rear tread	b11(mm)		/		
	Dimensions and Overall Sizes	4.1	Lift rotation/fork carriage forwards/backwards	Gradi		1,4 / 4 ⁽²⁾	
4.2		Height, mast lowered	h1 (mm)	2123 - 2003 ⁽¹⁾	2178 - 2058 ⁽¹⁾	2230 - 2110 ⁽¹⁾	
4.3		Free lift	h2 (mm)	1580 - 1460 ⁽¹⁾	1633 - 1513 ⁽¹⁾	1685 - 1565 ⁽¹⁾	
4.4		Lift	h3 (mm)	1600 - 1480 ⁽¹⁾	3520 - 3280 ⁽¹⁾	5253 - 4893 ⁽¹⁾	
4.5		height mast slipped off	h4 (mm)	2143 - 2023 ⁽¹⁾	4063 - 3823 ⁽¹⁾	5796 - 5436 ⁽¹⁾	
4.7		Height of overhead guard (cabin)	h6 (mm)		2120 - 2000 ⁽¹⁾		
4.8		Seat height / stand height	h7 (mm)		95 / 195		
4.19		Overall length	l1 (mm)		2402 - 2460 ⁽³⁾		
4.20		Length to face of forks	l2 (mm)		1252 - 1310 ⁽³⁾		
4.21		Overall width	b1 (mm)		850		
4.22		Fork dimensions	sel (mm)		40 / 80 / 1150		
4.23		Fork carriage DIN 15173, Class/type, A,B			2 / A		
4.24		Width portable fork carriage	b3 (mm)	820	612	612	
4.25		Distance between fork-arms	b5 (mm)		540 - 525 ⁽²⁾ - 584 ⁽³⁾		
4.31		Ground clearance, laden, below mast	m1 (mm)	63	48	48	
4.32		Ground clearance, centre of wheelbase	m2 (mm)		56		
4.33		Aisle width for pallets 1000 x 1200 crossways	Ast3 (mm)		2600 - 2653 ⁽³⁾		
4.34		Aisle width for pallets 800 x 1200 crossways 800	Ast3 (mm)		2711 - 2767 ⁽³⁾		
4.35		Turning radius	Wa (mm)		1114		
Performance		5.1	Travel speed (laden/unladen)	km/h		8 / 9	
	5.2	Lifting speed (laden/unladen)	m/s	0,17 / 0,27	0,16 / 0,26	0,16 / 0,25	
	5.3	Lowering speed (laden/unladen)	m/s		0,3		
	5.7	Surmountable tilt KB 30 (laden/unladen)	%		/		
	5.8	Surmountable tilt KB 5 (laden/unladen)	%		8 / 15		
	5.9	Acceleration time, laden/unladen	s		/		
	5.10	Service brake			Hydraulic pedal operated		
	Engine	6.1	Drive motor, rating KB 60	Kw		3	
		6.2	Lift motor, rating 15% ED	Kw		2,2	
		6.3	Battery acc. DIN 43531/35/36; A, B, C,			DIN 43535-B	
6.4		Voltage / nominal capacity	V / Ah		24 / 375 - 435		
6.5		Battery weight (+-5%)	Kg		385		
6.6		Energy consumption acc. to VDI cycle	KWh/h		/		
Others	8.1	Drive type			Electronic		
	8.2	Operating pressure for attachments	bar		/		
	8.3	Oil volume for attachments	l/min		/		
	8.4	Sound level at the driver's ear	dB (A)		<70		

The values presented are to be taken as indicative and not binding; they refer to the standard equipment

(1) "C" version values
 (2) fork rotation optional
 (3) value with option of lateral travel forks (with or without rotation)

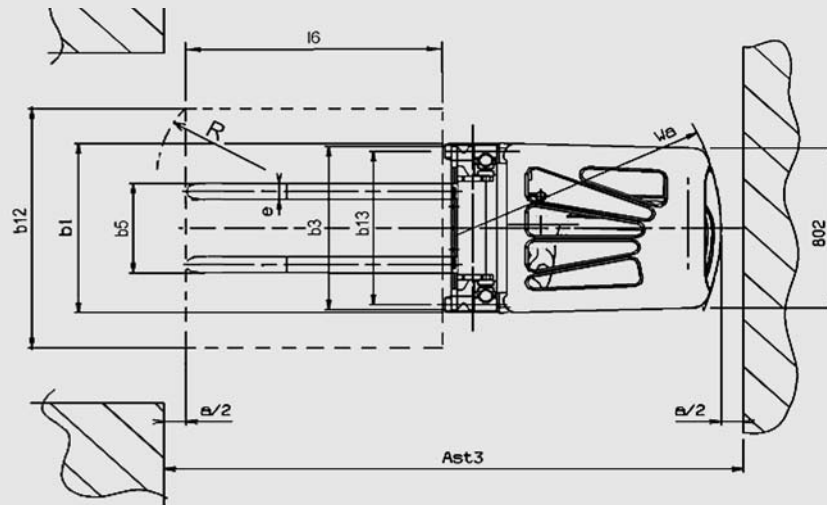
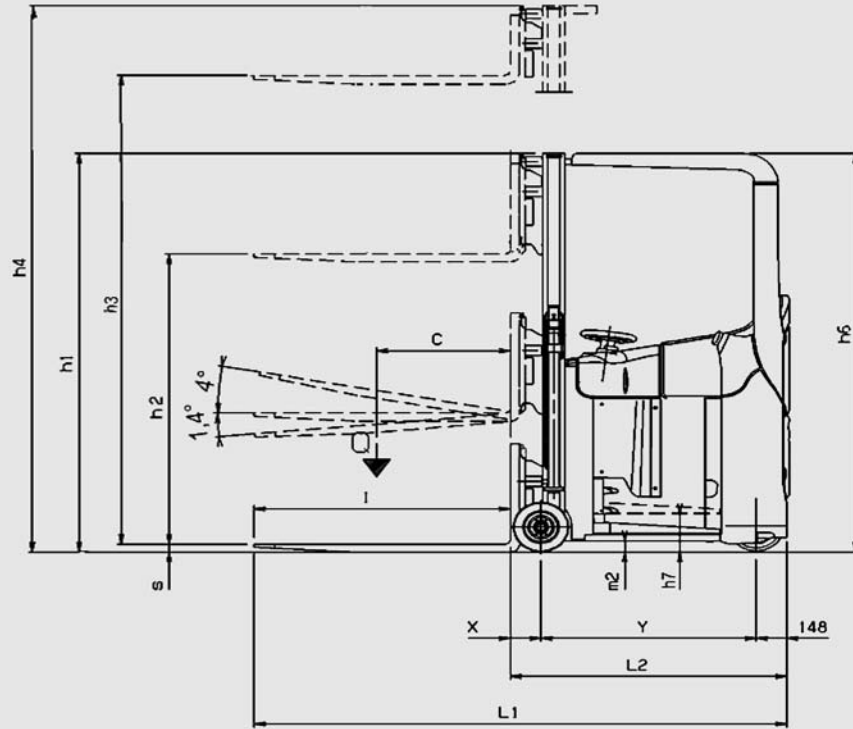

IDEA

The new way to drive



Innovation at the service of versatility: Agreeable style, linea compactness, soft rounded shapes, high technology, attention to detail, maximum safety: all this is **IDEA**. Comfortable, compact, manageable, extremely versatile, and capable of transporting loads of up to 1000 Kg to heights of 5.253 mm. Only 850 mm wide, and with minimal height size with completely changeable forks outside the truck which make loading and unloading operations possible from the ground, and it moves easily in narrow aisles. Capable of carrying out any activity, even those that previously required specialist vehicles, and is articularly suitable in the case of continuous variations of backward and forward drive. **IDEA** seems to have been designed by the driver.

Ergonomics and comfort: The driving position has been designed on the basis of the most modern ergonomic and functional principles in order to let the operator maintain the same level of efficiency throughout the work shift. Suitable for people of varying weight, it is characterised by rounded shapes, floor covered in soft anti-slip rubber, enveloping side cushion in athermic material and accessorised with useful storage trays or drinks holder. Provided with stationary braking system which is activated automatically in the absence of the operator, braking on release of the drive controls allowing a gradual stop in the space of a few metres and cross flow braking in addition to braking with the pedal on the load wheels, **IDEA** makes all manoeuvres precise and safe.

The extremely simple controls, concentrated on the steering wheel and the multi-function lever, are activated respectively by the right and left hand: The operator's position is therefore stable and safe. The ergonomic shape and the reduced dimensions of the hydraulically servo-assisted steering wheel, ensure maximum driving comfort making all the activation easy and gradual, even at low speed conditions and in reduced work spaces.

The multi-function lever, which houses all the controls for forward-reverse gears, stop, lifting and lowering of the load, forks rotation (optional) can be activated simply and immediately, without having to change the position of the hand.

Hour meter, battery level indicator, steering wheel position indicator (optional) make it possible to keep the state of the forklift under control.

The footboard, at only 95mm from the ground, can be hydraulically regulated in height.

The operator finds himself in a position which is diagonal in respect to the driving direction, maintaining a good view both forward and backward; no twisting of the body at each change of direction and therefore no unnecessary exertion.

Just a few minutes are all that is needed to get used to the forklift, and the operator will be able to move in total ease and maximum speed.

Versatility: Capable of carrying all types of load which can be positioned onto forks, IDEA is particularly suitable for: ■ service in any warehouse with or without shelving; ■ supplying production lines; ■ supplying trilateral overhead plant; ■ truck loading and unloading operations.

Optimum views on all sides and upwards thanks to the great visibility lift and to the protective radial overhead guard. The operator can then at any time check, without any effort, the forklift and the load being transported, and move in total safety and efficiency.

**Technical data are given as an indication.
OM Carrelli Elevatori reserves the right to modify them without notice.**



OM Carrelli Elevatori S.p.A.
Viale A. De Gasperi, 7
I-20020 Lainate (MI)
Tel.: +39(02)937 65-1
Fax: +39(02)937 65-450
www.om-mh.com