

XE 22^{ac} - 30^{ac} Technical Data



XE 22^{ac} - 30^{ac} Technical Data

VDI 2198

Specification	1.1	Manufacturer		OM	OM	OM	OM
	1.2	Manufacturer's type designation		XE 22 ^{ac}	XE 25 ^{ac}	XE 25L ^{ac}	XE 30 ^{ac}
	1.3	Drive: electric - diesel - petrol - LPG - mains electricity		Electric	Electric	Electric	Electric
	1.4	Operator type: Hand-towed - On foot - Standing - Driver seated		Driver seated	Driver seated	Driver seated	Driver seated
	1.5	Nominal range	Q (t)	2,2 ⁰⁾	2,5 ⁰⁾	2,5 ⁰⁾	3,0 ⁰⁾
	1.6	Load centre distance	c (mm)	500	500	500	500
	1.8	Distance fork level from the front axle	x (mm)	435	435	435	440
	1.9	Wheelbase	y (mm)	1546	1546	1690	1690
	Weights	2.1	Weight in running order	kg	4385	4660	4725
2.2		Axle weight with nominal load front/rear	kg	5885/700	6360/800	6605/620	7220/810
2.3		Axle weight unloaded front/rear	kg	2360/2025	2335/2325	2545/2180	2550/2480
Wheels and Tyres	3.1	Tyres: SE = super-elastic - CU = cushion - PN = pneumatic		SE / SE ¹⁾	SE / SE ¹⁾	SE / SE ¹⁾	SE / SE ¹⁾
	3.2	Dimensions front wheels		23x9-10	23x9-10	23x9-10	23x9-10
	3.3	Dimensions rear wheels		18x7-8	18x7-8	18x7-8	18x7-8
	3.5	Wheels: N _i front/N _j rear (x = drive wheels)		2x/2	2x/2	2x/2	2x/2
	3.6	Front track	b10 (mm)	993	993	993	993
	3.7	Rear track	b11 (mm)	994	994	994	994
	Dimensions and Overall Sizes	4.1	Inclination lifting group forward/reverse	Grad	5°/7° ⁴⁾	5°/7° ⁴⁾	5°/7° ⁴⁾
4.2		Minimum encumbrance height lift	h1 (mm)	2555	2555	2555	2555
4.3		Free lift	h2 (mm)	150	150	150	150
4.4		Lifting height	h3 (mm)	3350	3350	3350	3350
4.5		Maximum encumbrance height lift	h4 (mm)	4155	4155	4155	4155
4.7		Height of protective roof	h6 (mm)	2250 ²⁾	2250 ²⁾	2250 ²⁾	2250 ²⁾
4.8		Height of seat	h7 (mm)	1154	1154	1154	1154
4.12		Height of tow hook	h10 (mm)	485	485	485	485
4.19		Overall length	l1 (mm)	3330	3330	3474	3474
4.20		Length (including thickness of the forks)	l2 (mm)	2330	2330	2474	2474
4.21		Maximum width	b1/b2 (mm)	1200	1200	1200	1200 ¹⁾
4.22		Dimensions of forks	s/e/l (mm)	45/100/1000	45/100/1000	45/100/1000	45/100/1000
4.23		Fork carriage plate to DIN 15173 Class / Form A, B		2A	2A	2A	3A
4.24		Fork carriage plate width	b3 (mm)	1150	1150	1150	1150
4.31		Height of masts from ground (loaded)	m1 (mm)	155	155	155	155
4.32		Height centre of chassis from ground (loaded)	m2 (mm)	110	110	110	110
4.33		Aisle width for pallet 1000x1200 and crossways 1200	Ast (mm)	3640	3640	3785	3790
4.34		Aisle width for pallet 800x1200 and crossways 800	Ast (mm)	3770	3770	3915	3920
4.35		Turning circle	Wa (mm)	1886	1886	2030	2030
4.36		Minimum distance of the point of rotation from the middle of the forklift	b13 (mm)	-	-	-	-
Performance	5.1	Speed of travel with/without load	km/h	20/20	20/20	20/20	20/20
	5.2	Speed of lifting with/without load	m/s	0.56/0.58	0.56/0.58	0.56/0.58	0.50/0.58
	5.3	Speed of lowering with/without load	m/s	0.56/0.52	0.56/0.52	0.56/0.52	0.56/0.52
	5.5	Traction force at the hook (S2 60 min) with/without load	N	4200/4500	4150/4500	4100/4500	3900/4400
	5.6	Maximum traction force at the hook (S2 5 min) with/without load	N	13500/13500	13500/13500	13500/13500	13500/13500
	5.7	Gradient which can be travelled (S2 30 min) with/without load	%	11/16	10/16	9/15	8/14
	5.8	Maximum gradient which can be travelled (S2 5 min) with/without load	%	20/29	19/28	18/27	17/26
	5.9	Acceleration time (10 m), with/without load	s	4.3/3.9	4.4/4.0	4.4/4.0	4.5/4.0
	5.10	Service brake		Electro-Mechanical	Electro-Mechanical	Electro-Mechanical	Electro-Mechanical
	Engine	6.1	Drive motor rating S2 60 min	kW	2 x 8	2 x 8	2 x 8
6.2		Lifting motor rating S3 15%	kW	22	22	22	22
6.3		Battery to DIN 43531/35/36 A, B, C, NO		DIN 43536 A	DIN 43536 A	DIN 43536 A	DIN 43536 A
6.4		Voltage, battery capacity K5	V / Ah	80/560 ³⁾	80/560 ³⁾	80/625 ³⁾	80/625 ³⁾
6.5		Weight of battery	kg	1540	1540	1863	1863
6.6		Energy consumption acc. to VDI cycle	kWh/h	-	-	-	-
Others	8.1	Type of start control		Inverter	Inverter	Inverter	Inverter
	8.2	Working pressure per fitting	bar	150	160	160	175
	8.3	Oil capacity per fitting (max. available)	l/min	50	50	50	55
	8.4	Noise level at level of operator's ears to EN 12053	dB (A)	<70	<70	<70	<70
	8.5	Tow hook, model/type DIN		-	-	-	-

The values presented are to be taken as indicative and not binding; they refer to the standard equipment

0) The effective ranges are a function of the position of the centre of gravity of the load, of the type of lift, of the lifting height, the tyres and of any fittings

1) For alternative wheels see the table "annex wheels" front SE 23x10-12 (compulsory) standard fitted only for TX on XE 30^{ac} with h3 = 5975 mm and h3 = 6725 mm; consequently max. width b1/b2 1266 mm

2) h6=2120 mm per version with roof lowered

3) Battery optional 80V (capacity/weight): 620Ah/1540kg (XE22^{ac} and XE25^{ac}); 700Ah/1863kg and 775Ah/1863kg (XE25L^{ac} and XE30^{ac})

4) for all SX and DX 5°/7°, excepted SX with h3 = 5050 mm (3° / 7°) For all TX with h3 < 4500 mm with tilting 5° / 4°, for all TX with h3 > 4500 mm tilting 3° / 7°

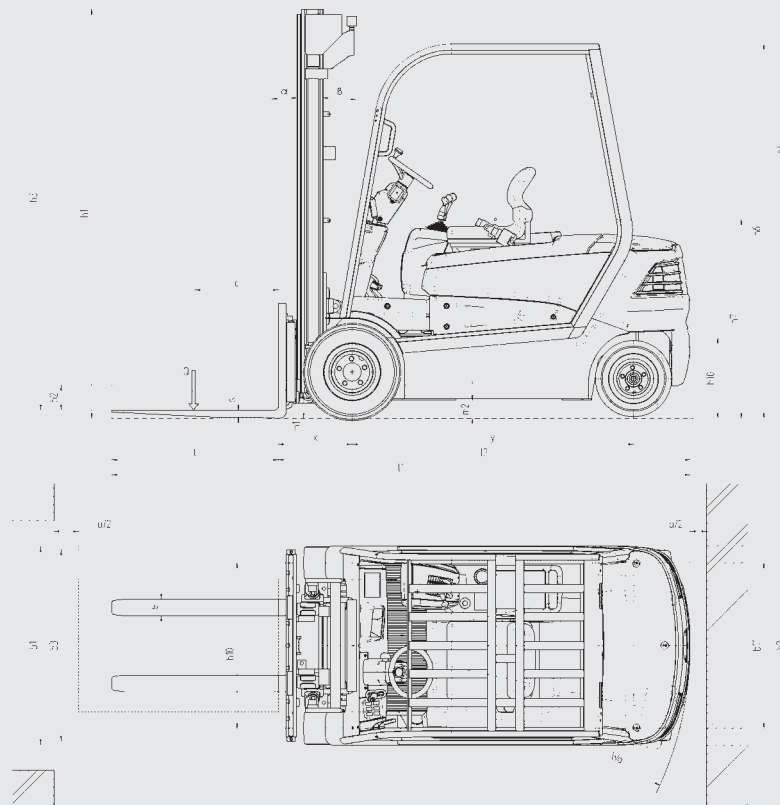

CHARACTERISTICS OF ALTERNATIVE LIFTS

			Simplex					Duplex			Triplex								
XE 22 ^{ac}	Lifting height	h ₃	mm	3350	3650	4050	4450	5050	3350	3650	4050	3875	4025	4175	4325	4625	5225	5975	6725
	Height, minimum dimension	h ₁	mm	2555	2705	2905	3105	3405	2410	2560	2760	2060	2110	2160	2210	2310	2510	2760	3010
	Height, maximum dimension	h ₄	mm	4155	4455	4855	5255	5855	3985	4285	4685	4510	4660	4810	4960	5260	5860	6610	7360
	Free lift	h ₂	mm	150	150	150	150	150	1775	1925	2125	1425	1475	1525	1575	1675	1875	2125	2375
XE 25 ^{ac}	Lifting height	h ₃	mm	3350	3650	4050	4450	5050	3350	3650	4050	3875	4025	4175	4325	4625	5225	5975	6725
	Height, minimum dimension	h ₁	mm	2555	2705	2905	3105	3405	2410	2560	2760	2060	2110	2160	2210	2310	2510	2760	3010
	Height, maximum dimension	h ₄	mm	4155	4455	4855	5255	5855	3985	4285	4685	4510	4660	4810	4960	5260	5860	6610	7360
	Free lift	h ₂	mm	150	150	150	150	150	1775	1925	2125	1425	1475	1525	1575	1675	1875	2125	2375
XE 25L ^{ac}	Lifting height	h ₃	mm	3350	3650	4050	4450	5050	3350	3650	4050	3875	4025	4175	4325	4625	5225	5975	6725
	Height, minimum dimension	h ₁	mm	2555	2705	2905	3105	3405	2410	2560	2760	2060	2110	2160	2210	2310	2510	2760	3010
	Height, maximum dimension	h ₄	mm	4155	4455	4855	5255	5855	3985	4285	4685	4510	4660	4810	4960	5260	5860	6610	7360
	Free lift	h ₂	mm	150	150	150	150	150	1775	1925	2125	1425	1475	1525	1575	1675	1875	2125	2375
XE 30 ^{ac}	Lifting height	h ₃	mm	3350	3650	4050	4450	5050	3350	3650	4050	3875	4025	4175	4325	4625	5225	5975	6725
	Height, minimum dimension	h ₁	mm	2555	2705	2905	3105	3405	2410	2560	2760	2060	2110	2160	2210	2310	2510	2760	3010
	Height, maximum dimension	h ₄	mm	4155	4455	4855	5255	5855	4135	4435	4835	4660	4810	4960	5110	5410	6010	6760	7510
	Free lift	h ₂	mm	150	150	150	150	150	1625	1775	1975	1275	1325	1375	1425	1525	1725	1975	2225

Attached - height of lifts: technical file VD12198 XE22-30^{ac}

WHEELS

Type	Superelastic (SE)		Pneumatic (PN) (For all mast SX and DX - no for TX mast)	
	Front	Rear	Front	Rear
XE 22 ^{ac}	-	-	23x9-10 / 20 pr	18x7-8 / 16 pr
XE 25 ^{ac}	-	-	23x9-10 / 20 pr	18x7-8 / 16 pr
XE 25L ^{ac}	-	-	23x9-10 / 20 pr	18x7-8 / 16 pr
XE 30 ^{ac}	23x10-12 ¹⁾	18x7-8	23x9-10 / 20 pr	18x7-8 / 16 pr

XE 22^{ac} - 30^{ac}

Electric counterbalanced forklift-truck.



The many years of collaboration with the Zagato Design Studio have led to the new XE 22-30^{ac} in the electric counterbalanced forklift-trucks range built by OM. Its unmistakable **design** translates into authentic Italian style the highest level of comfort and ergonomics for the operator. Electrically powered, of compact dimensions and with a high degree of manoeuvrability, it's the perfect tool for indoor and outdoor warehouse logistics and in truck loading and unloading operations.

Comfort and ergonomics mean increased productivity: the operator module is completely suspended - F. S. C. system Full suspended Cab - in order to reduce vibrations to the minimum level for the driver. The Grammer MSG 20 seat is included in the standard version, the MSG 65 super comfort seat is provided as an option. All the controls are easily accessible and ergonomically placed at the operator's reach. The hydraulic levers, positioned on the right side of the operator, near the body allow a perfect control of the movements of the mast, thus increasing safety as well as the overall quality of the handling operations.

The new **AC** electronic controller with its **CANBUS** technology, manage all the functions of the forklift and its self-diagnostic systems. The power system is perfectly tuned both for extreme accuracy and for high performance operations.

The new JULI front axle incorporates **two 80 Volts AC motors** with 8kW of power each. The motors, with their very high torque output together with the electronic controller represent the beating heart of the forklift.

The traction system thus delivers the best combination of performance, reduced energy consumption, effective regenerative braking and zero maintenance. The electronics also allow the use of the twin traction motors as an **advanced electronic differential**: on uneven or slippery surfaces the traction is always transmitted to the two front wheels obtaining increased grip and control from the forklift truck. The twin motors system also allows the truck to turn on its own length as if it was a three wheels truck.

The new steering axle delivers maximum manoeuvrability even in very narrow spaces. To avoid dangerous conditions increasing safety, the electronic controller detects the angle of the wheels and in tight corners it automatically slows the truck down.

The hydraulics functions are operated by a **powerful 80V-22kW AC motor**. The 80V batteries conform to DIN norms and have a capacity range from 560 to 775 Ah.

The new **LCD display** is easily readable at a glance in every lighting condition; it's a really useful working tool showing all the necessary data to the operator: the battery charge level, the position of the steering wheels, the hour meter, the need for maintenance, the selected operating profile and much more.

The operator can choose in a simple way directly with the buttons on the display three different **preset profiles, one of which can be customized**: maximum performance or maximum battery saving independently for traction and lifting.

The new mast, designed and produced in co-operation with Linde, delivers high residual capacities, excellent visibility and unbeatable durability. Simplex, Duplex and Triplex masts are available, with heights ranging up to 6725 mm. An extensive list of options is available to perfectly match your own specific requirements!

Technical data are given as an indication.
OM Carrelli Elevatori reserves the right to modify them without notice.

OM Carrelli Elevatori S.p.A.
Viale A. De Gasperi, 7
I-20020 Lainate (MI)
Tel.: +39(02)937 65-1
Fax: +39(02)937 65-450
www.om-mh.com

